

SCREATURE™

INTERACTIVE DINOSAUR
A ROBOTICALLY RECREATED PREDATOR

INSTRUCTIONS

4+



Keep these instructions for future reference as they contain important information.

Requires 3 "AA" alkaline batteries. Batteries included are for demonstration purposes.



N4320-0920

BATTERY INSTALLATION/REPLACEMENT

1. Open battery cover with a Phillips head screwdriver (not included). Remove batteries included for demonstration purposes and dispose of them safely. [Remove the two upper batteries. Pull up on the ribbon to remove the lower battery.]

2. Insert one "AA" battery into the lowest compartment, in the orientation shown, on top of ribbon.

3. Install 2 "AA" batteries into top compartment, in the orientation shown. Replace battery cover and tighten screws.

Replace batteries when toy slows down, stalls, or sounds become distorted. For best performance, use only alkaline batteries.

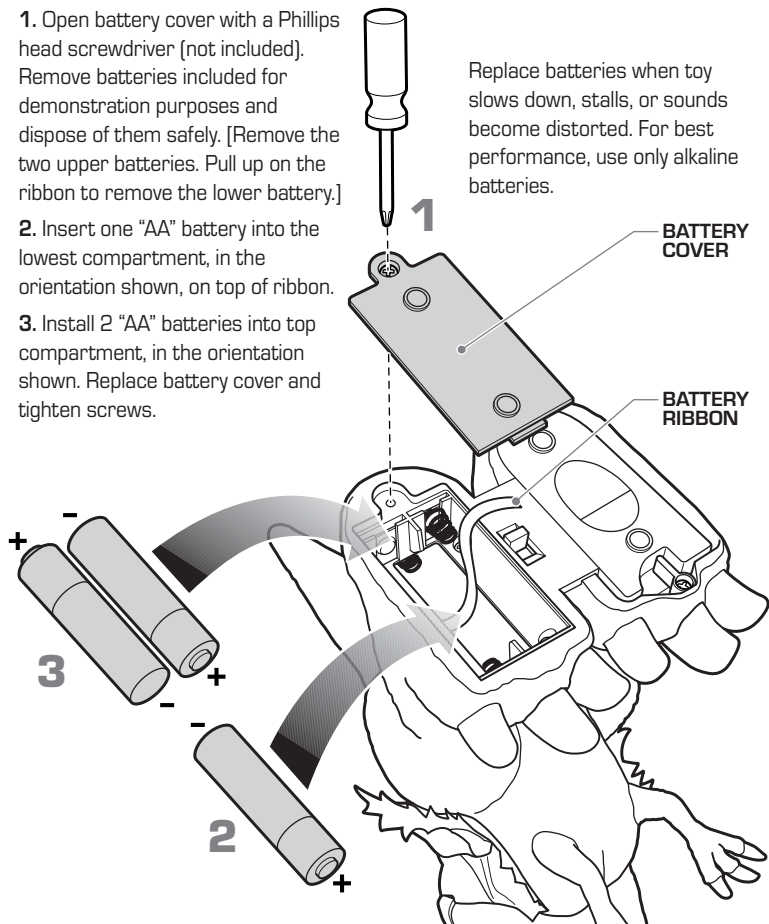

GET READY

1. Open the water canister latch.
2. Remove the water canister.
3. Fill canister with water.

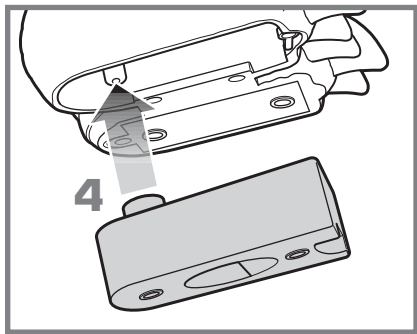
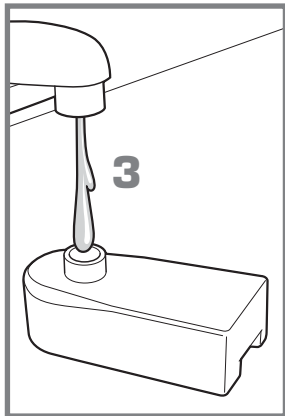
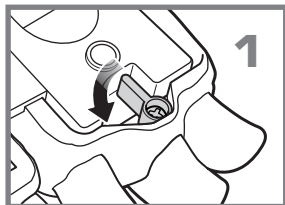
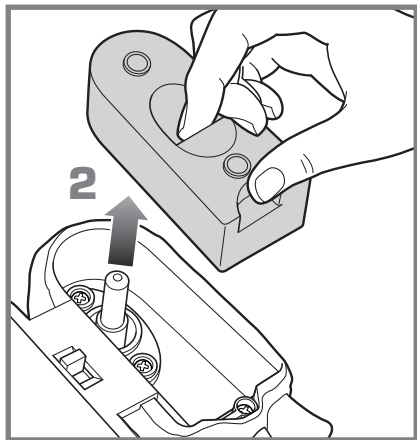

4. Holding SCREATURE™ upright, slide water canister upward onto tube and close latch.

Use only water to fill the water canister. Do not use any other fluids in the canister to avoid damaging SCREATURE™.

SENSORS

NOSE
SENSOR

LIGHT
SENSOR

PETTING
SENSOR

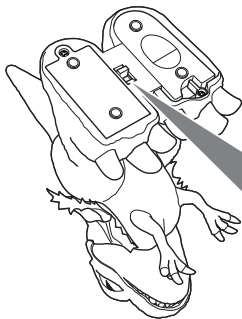
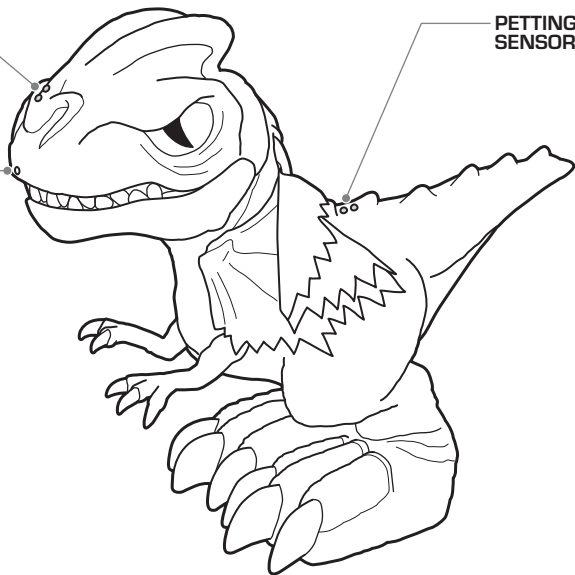

LET'S PLAY

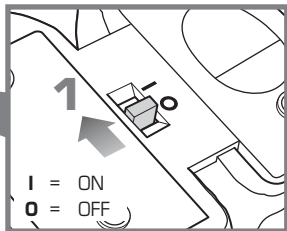

1. Turn on
SCREATURE™
as shown. He
will yawn as
if he's just
waking up.

WAYS TO PLAY

With a playful yet *biting* personality, SCREATURE™ is one feisty predator! Are you tough enough to tame him? Or will he shower you with his surprise attack?



PET: SCREATURE™ likes when you pet him on the back. Touch his petting sensor, then remove your fingers to make him pant in appreciation!

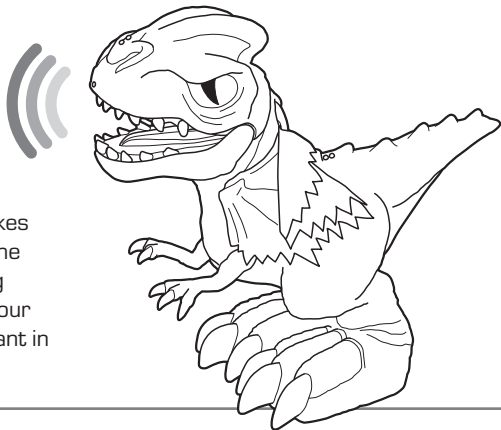

SNAP: If he senses you reaching for his nose, he will snap forward. Surprise your friends by asking them to try this!



WAYS TO PLAY *(Continued)*



LAUGH: Touch both his nose and petting sensors at the same time to tickle SCREATURE™ and make him laugh.

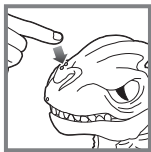
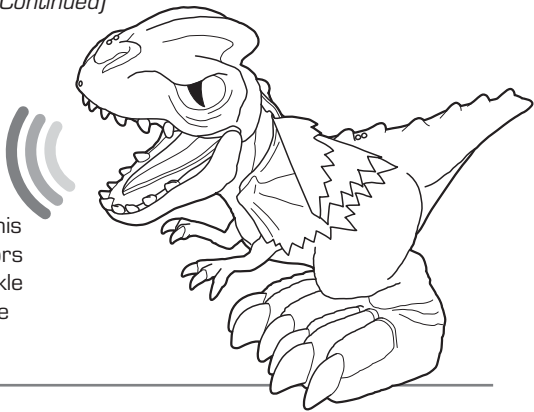

SPIT: Touch his nose sensor; then remove your fingers to make SCREATURE™ rise up, extend his neck frills and spit water. This is his surprise attack!

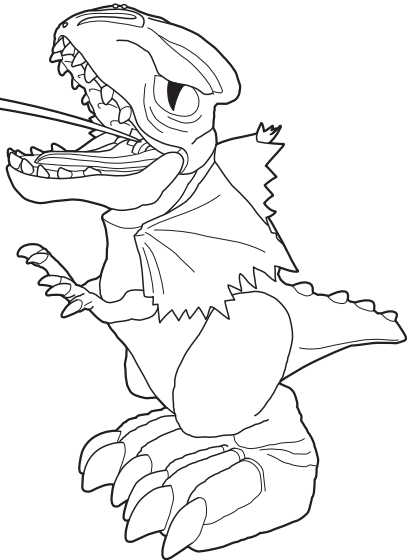

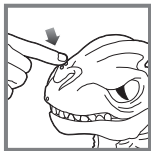

GUARD MODE: Touch and hold his nose sensor for 3 or more seconds, then remove your fingers and SCREATURE™ will rear up and stand guard. If he senses any motion near him, he will roar and spit water. Touch either his petting or nose sensor to de-activate GUARD MODE.

SLEEP: After 2 minutes of inactivity, SCREATURE™ will fall asleep. He can be awakened by pressing his nose or petting sensor, or by turning him **OFF** and then **ON** again.

TRAINING TIP: Since SCREATURE™ is such a lively dinosaur, he can get a bit jumpy after being picked up. While holding him, make sure to keep him still or he may snap at you. When moving him, cover his light sensor to prevent him from snapping.

TROUBLESHOOTING

Check the batteries if SCREATURE™ is not functioning properly. If the batteries are OK and he's still not working, try switching him **OFF**, pausing 5 seconds and turning him back **ON**.

KEEP YOUR DINO WORKING PROPERLY

- SCREATURE™ works best on a smooth, hard surface.
- SCREATURE™ is not recommended for use on loose dirt or wet surfaces.
- Do not immerse SCREATURE™ in water.
- Water toys sometimes get messy, so please protect play surfaces before use. Do not use on surfaces that can be damaged by water.
- When you are through playing, drain, rinse, clean and dry all items, including canister, thoroughly before storing.
- The nose and petting sensors will malfunction if they get wet. Make sure your hands and SCREATURE™ are dry before play.

BATTERY SAFETY INFORMATION

In exceptional circumstances batteries may leak fluids that can cause a chemical burn injury or ruin your product. To avoid battery leakage:

- Non-rechargeable batteries are not to be recharged.
- Rechargeable batteries are to be removed from the product before being charged (if designed to be removable).
- Rechargeable batteries are only to be charged under adult supervision (if designed to be removable).
- Do not mix alkaline, standard (carbon-zinc), or rechargeable (nickel-cadmium) batteries.
- Do not mix old and new batteries.
- Only batteries of the same or equivalent type as recommended are to be used.

- Batteries are to be inserted with the correct polarity.
- Exhausted batteries are to be removed from the product.
- The supply terminals are not to be short-circuited.
- Dispose of battery(ies) safely.
- Do not dispose of this product in a fire. The batteries inside may explode or leak.
- Do not connect to more than the recommended number of power supplies.



Protect the environment by not disposing of this product with household waste (2002/96/EC). Check your local authority for recycling advice and facilities.

©2008 Mattel, Inc. All Rights Reserved.

Mattel, Inc., 333 Continental Blvd., El Segundo, CA 90245 U.S.A. Consumer Relations 1 (800) 524-8697. Retain this address for future reference. • Mattel Canada Inc., Mississauga, Ontario L5R 3W2. You may call us free at 1-800-524-8697. • Mattel U.K. Ltd., Vanwall Business Park, Maidenhead SL6 4UB, Helpline 01628 500303. • Mattel East Asia Ltd., Room 1106, South Tower, World Finance Centre, Harbour City, Tsimshatsui, HK, China. • Diimport & Diedarkan Oleh: Mattel SEA Ptd Ltd. (993532-P) Lot 13.5, 13th Floor, Menara Lien Hoe, Persiaran Tropicana Golf Country Resort, 47410 PJ. Tel: 03-78803817, Fax: 03-78803867.

service.mattel.com